

PCB LAYOUT MOUNTING PATTERN

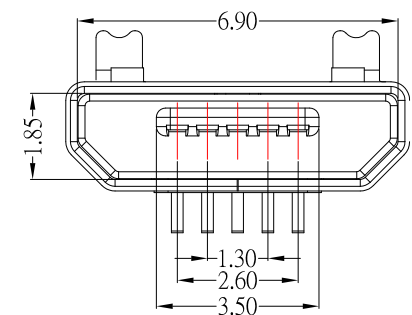

NOTES:

MATERIAL:

- 1.1 HOUSING: LCP
- 1.2 CONTACT: BRASS
- 1.3 SHELL: SUS

Finish:

- 2.1 Contact: Plated Gold in Mating Area ;
Gold Plated on Solder Balls
Nickel under plated overall
- 2.2 Shell: Nickel under Plated surface layer

3.SPECIFICATION:

- 3.1 CURRENT RATING: 1.0A
- 3.2 DIELECTRIC WITHSSTANDING VOLTAGE: 100 V(ac) FOR 1min
- 3.3 CONTACT RESISTANCE: 30 mΩ MAX.
- 3.4 INSULATION RESISTANCE: 100 MΩ MIN.
- 3.5 TOTAL MATING FORCE: 3.57 Kgf MAX.
- 3.6 TOTAL UNMATING FORCE: 1.0 Kgf MIN.
- 3.7 TEMPERATURE RANGE: -30°C ~ +80°C

8	更新圖面	Jack	030221	10	新增尺寸	Jack	040721
7	新增PCB LAYOUT尺寸	Jack	052620	9	新增尺寸	Jack	033121

6	更新外觀鍍線	Jack	042420
5	更新尺寸	Jack	030220
4	新增PIN編號	Jack	050319
3	更新圖面	Jack	042619
2	新增PCB LAYOUT尺寸	Jack	010319
1	更新為A0版	Jack	041718
ITEM NO.	DESCRIPTION	DRAWN	DATE



TOLERANCE UNLESS OTHERWISE STATED :	Up to 5 ±0.2	3RD. ANGEL'S	UNITS	MM
	Above 5 ~ 15 ±0.3			
	Above 15 ~ 30 ±0.4			
	Above 30 ~ 50 ±0.5			
	Angle ±0.3°			

DRAWN BY:	DATE	MAT'L	TITLE	CONNECTOR
Jack Lu	04/07/21			
CHECKED BY:	DATE	FINISH	MODLE	MICRO USB 5P 直立式SMT,無捲邊
Jacky Chen	04/07/21			
APPROVED BY:	DATE	SCALE	DWG NO.	MRUSB-5B-VS7NI-S306
Tony Kao	04/07/21	1 : 1		
		SHEET NO.	PART NO.	MRUSB-5B-VS7NI-S306
		1 of 1		
				SIZE A4
				VER R10